

Solid-liquid mixture flow through a slim hole annulus with rotating inner cylinder[†]

Sang-mok Han, Nam-sub Woo, and Young-kyu Hwang^{*}

School of Mechanical Engineering, Sungkyunkwan University, 300 Chunchun-dong, Jangan-gu, Suwon 440-746, S. Korea

(Manuscript Received May 2, 2008; Revised September 29, 2008; Accepted October 30, 2008)

Abstract

An experimental study was conducted to study solid-liquid mixture upward hydraulic transport of solid particles in vertical and inclined annuli with rotating inner cylinder. Lift forces acting on a fluidized particle play a central role in many important applications, such as the removal of drill cuttings in horizontal drill holes, sand transport in fractured reservoirs and sediment transport, etc. Annular fluid velocities varied from 0.4 m/s to 1.2 m/s. Effect of annulus inclination and drill pipe rotation on the carrying capacity of drilling fluid, particle rising velocity, and pressure drop in the slim hole annulus have been measured for fully developed flows of water and of aqueous solutions of sodium carboxymethyl cellulose (CMC) and bentonite, respectively. For higher particle feed concentration, the hydraulic pressure drop of mixture flow increases due to the friction between the wall and solids or among solids.

Keywords: Solid-liquid mixture flow; Slim hole annulus; Particle concentration; Pressure drop

1. Introduction

Among the various industrial unit operations involved with multi-phase systems, agitation of solid-liquid systems is quite commonly encountered such as in catalytic reactions, drilling operation of oil well, sand transport in fractured reservoirs, etc. Although there are many industrial applications of solid-liquid mixture flows in technology, the available knowledge about particle flows is incomplete due to the difficulties encountered in analyzing these complex systems.

Due to the variety of the parameters related to the solid-liquid mixture flow, there may be various conditions to be included in considering the influence of the variables related to the transportation of drill cuttings. The study of transportation drill cuttings is a case of engineering that is classified as multi-phase flow accompanying solid particle, fluid and gas.

[†] This paper was recommended for publication in revised form by Associate Editor Gihun Son

^{*} Corresponding author. Tel.: +82 31 290 7437, Fax.: +82 31 290 5889

E-mail address: ykhwang@skku.edu

© KSME & Springer 2009

The study of drill cuttings transportation ability can be divided into the dynamics of the particles within the fluid largely and can be divided into the specialty and action of the drilling irrigation.

When an oil well is drilled, it is necessary to transport the cuttings up to the surface. To this end, drilling fluid is pumped through the center of the drill pipe and back up to the surface through the annular gap between the drill pipe and the drilled hole. The flow up to the annulus might be laminar or turbulent, depending on the situation.

With the increase in use of deviated, highly deviated and long reach drilling, greater consideration must be given to the fluid mechanics of transportation in situations where none, or only a small component, of the bulk flow acts against the tendency for cuttings to drop out of suspension and form a bed on the low side of the annulus. This is even more important in a slim hole drilling which has small gap between the drill pipe and drilled hole.

Therefore, numerous mathematical and empirical models for the prediction of cuttings transport in hori-

zontal and directional wells have been developed. Tomren et al. [1] and Ford et al. [2] did experimental studies on cuttings transport in inclined annulus and observed the existence of different layers that might occur during the mud flow and cuttings in an annulus. They noted that rotation of the drill pipe has little effect unless the annulus is eccentric and the drill pipe is on the low side of a horizontal geometry.

Interest has been growing in the interaction between particle and local flow structure in particulate solid-liquid mixture flow. Pigot [3] discussed the application of Stoke's law for laminar flow and Rittinger's formula for turbulent flow to particle settling velocity calculation. He concluded that high fluid viscosity was not necessary and suggested that laminar flow in the annulus would lead to more efficient cleaning. For trouble-free operation, he also recommended that the volumetric cuttings concentration in the annulus be kept less than 5%.

Sifferman et al. [4] found that annular velocity and fluid rheological properties are the most important factors influencing the transport ability of a fluid. Other variables such as particle size, drill pipe rotation, drill pipe eccentricity have only moderate effects on carrying capacity in their study.

Sellgren [5] and Ozbelge et al. [6] discussed the solid-liquid mixture flow pressure drop and the choice of operating velocities in the vertical upward pipe flows of solid-liquid mixtures. They reported that additional turbulence was created due to the relative velocity between the solid and fluid phases.

This paper concerns an experimental study of fully developed solid-liquid mixture flow of Newtonian fluid, water and non-Newtonian fluid, CMC and bentonite solutions through a concentric annulus with combined bulk axial flow and inner cylinder rotation.

For inclined annulus, it is interesting to note that steady state conditions, as are known to be prevalent in most drilling operations, commence after the bed has already formed. Due to the constant interchange of particles between the bed and the flow stream, it is obvious that exact mathematical relations describing the free particle and steady bed dynamics will necessarily be quite formidable.

In an inclined annulus, bed formation of particles occurs only on the low side of the annulus due to gravity effects as depicted by Fig. 1. Any decrease in fluid velocity in the annular space in this vicinity will worsen the bed formation tendency. Although increasing inner pipe rotational speed generally improves particle

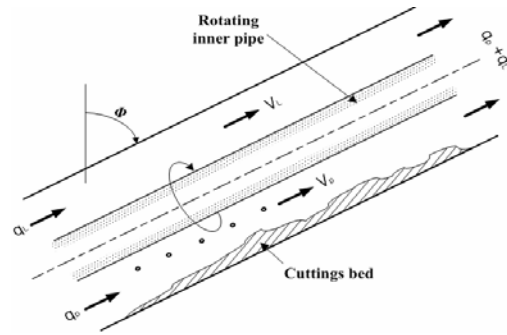

Fig. 1. Cuttings bed dynamics in an inclined annulus.

transport, it is more pronounced at lower annular fluid velocities and appears to be negligible at high velocities.

This study relates the physics of particle transportation and effective drilled cutting transportation in highly deviated wells. And this is one of the first studies conducted on experimental investigation of cuttings transport in highly deviated slim hole annulus. The flow characteristics of solid-liquid mixtures, flowing upward through a vertical annulus in a closed loop system, is determined by measuring the volumetric concentration of particles and the pressure drop in the test section. It is expected that the results of this study will be useful to explain the effect of solids on mixture flow transport phenomena in the annular geometry.

2. Experimental method

2.1 Experimental set-up and procedure

The objective of the solid-liquid mixture flow experiments was to provide high quality data on the effects of pipe rotation, flow regime, fluid properties, particle concentration on pressure loss in a slim hole annular flow.

The set-up used in the experiments is a closed-loop system consisting of a centrifugal slurry pump with a by-pass line, a vertical annulus and a feed slurry tank as shown in Fig. 2. The flow configuration and instrumentation are described by Kim and Hwang [7].

The outside diameter of the inner pipe (D_i) and the inside diameter of the outer pipe (D_o) being 30 mm and 44 mm, respectively, yield a radius ratio of 0.7 for the annulus. To ensure fully developed flow in the measuring section, the length of straight annulus upstream of the test section is 1.8 m, corresponding to 116 hydraulic diameters.

A cylindrical head tank was used for the prepara-

tion of feed particles. The tank has a conical bottom in order to avoid settling of the particles and it is connected from its bottom to a centrifugal pump with a flexible hose.

Pressure drop and averaged flow rate were measured in the flow range of $0.4 \text{ m/s} < v_m < 1.2 \text{ m/s}$. The flow rate was measured with a magnetic flow meter whose accuracy is within the limit of ± 0.5 percent. The inner cylinder may be rotated at any speed up to a maximum of 600 rpm by means of an A.C. motor.

The axial velocity of solid particles was measured by using a high speed CCD camera installed outside of the cylinder. The outer cylinder was made of transparent acryl pipe. The flow field was captured by an XC-55 CCD camera with 640×480 pixels, 8 bit resolution. The shutter speed was chosen to be 1/1000 s. The travel length of particle was measured in a BMP type photograph captured by CCD camera. And the velocity of particle was obtained by dividing time (30 frames per second). The experiment was repeated over 10 times for the same experimental condition and the particle rise velocity was averaged.

Static pressure was measured with static pressure tap of 0.5 mm diameter, distributed longitudinally in the outer cylinder. Two static pressure taps were installed along the flow direction in measuring part. The static pressures were read from a calibrated manometer bank with 1 mm resolution. The specific gravity of the manometer fluid CCl_4 is 1.88, and it gives a height in the range of 20–600 mm.

A short horizontal sampling line with a ball valve was constructed on the exit of the test section to measure the volumetric particle concentration. In each experimental run, a sample mixture fluid of approximately 500 cm^3 was collected from this sampling port without diverting the whole flow through the annulus. This procedure was repeated at least 5 times for the same experimental condition and the measured data were averaged.

First, experiments with water were performed to determine the accuracy of the present experimental set-up. Later, experiments with the solid-liquid mixtures were performed in a similar manner.

The head tank was filled with water up to a marked level and the pump was started. Particles at the desired feed particle concentration were prepared in the head tank by adding the uniformly sized sand particles. The mixture flow rate was adjusted manually by the by-pass valve installed after the outlet of the pump.

When the mixture flow became stable condition, the axial pressure drop, velocity of solid particles, and particle volume concentration were measured simultaneously. The mean diameter of sand particles of 0.2 cm and material density of 2.55 g/cm^3 were used in the experiment.

2.2 Fluid property

The drilling fluids usually have non-Newtonian properties. Non-Newtonian fluids are those for which the strain rate and stress curve are not linear, i.e., the viscosity of non-Newtonian fluids is not constant at a given temperature and pressure but depends on other factors such as the rate of shear in the fluid, the apparatus in which the fluid is contained or even the previous history of the fluid.

As shown by Lauzon and Leid [8], the power law model adequately describes most drilling fluids at shear rate normally encountered in wellbore annuli during normal drilling operation. The carrier fluids, 0.4% CMC and bentonite solutions, used in the experiment are shear-thinning.

In the case of CMC and bentonite solutions, $n < 1$ and the power law relating the shear stress τ to the shear rate $\dot{\gamma}$ is given by

$$\tau = k\dot{\gamma}^n \quad (1)$$

where, n is the flow behavior index and k is the consistency factor. The apparent viscosity μ_a for a power law fluid may be expressed in terms of n and k as follows:

$$\mu_a = k\dot{\gamma}^{n-1} \quad (2)$$

The effective viscosity of 0.4% CMC solution for the flow rate of 6 LPM becomes 16.5 cp at 0 rpm and

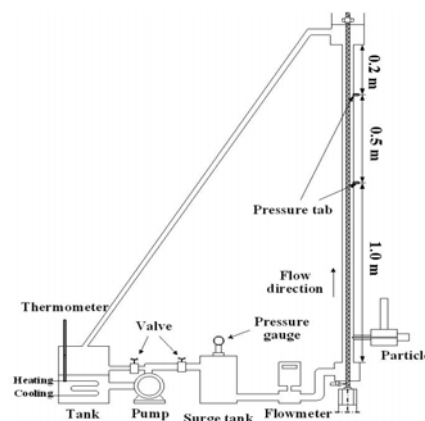

Fig. 2. Schematic diagram of experimental apparatus.

14.6 cp at 200 rpm and n is measured as 0.75, and that of 5% bentonite solution becomes 40.6 cp at 0 rpm and 35.9 cp at 200 rpm and n is measured as 0.73. The density of 0.4% CMC solution is 998.5 kg/m^3 and that of 5% bentonite solution is measured as 1041.1 kg/m^3 .

3. Results and discussion

Hydrodynamic characteristics of single phase flows are well known, but the same is not valid for solid-liquid mixtures and multi phase flows. In this study, the flow characteristics of solid-liquid mixture flows are investigated experimentally at different operating conditions.

The experimental parameters are the feed particle concentration, mixture velocity in the annulus, rotational speed of inner cylinder, and inclination angle of annulus. The important characteristics of solid-liquid flows in an annulus are the particle transport performance and the pressure drop versus mixture velocity relationship.

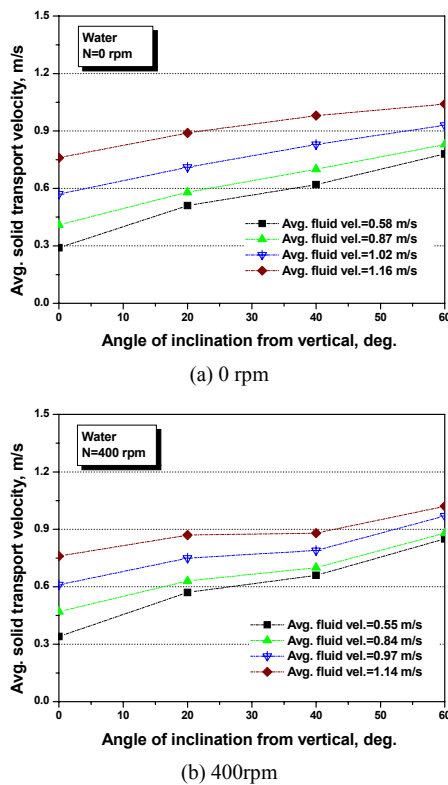

Fig. 3. Variation of particle rise velocity with annulus inclination and flow rate at (a) 0 rpm, and (b) 400 rpm in water.

Experiments were performed in turbulent flow using water and in laminar flow using 0.4% CMC and 5% bentonite solutions. The flow regime might be an important factor in cuttings transport due to changes in the velocity profile from laminar to turbulent flow.

Drilling fluids are able to transport cuttings to the surface principally by means of the fluid axial velocity. Due to the gravitational forces, the cuttings tend to slip downward or settle through the fluid medium as they are transported through the annulus.

Average particle rise velocity (v_p) measured by high speed CCD camera with mixture flow, rotation of the inner cylinder, and inclination of annulus is shown in Figs. 3 and 4. Particle velocity measurement experiment was carried out only in water and CMC solution.

As the annulus inclination increased over 20 degrees, more and more particles were forced toward the low side of the annulus, resulting eventually in the formation of a cuttings bed especially at low flow rates due to increasing radial slip velocity.

For both water and 0.4% CMC solution, the axial

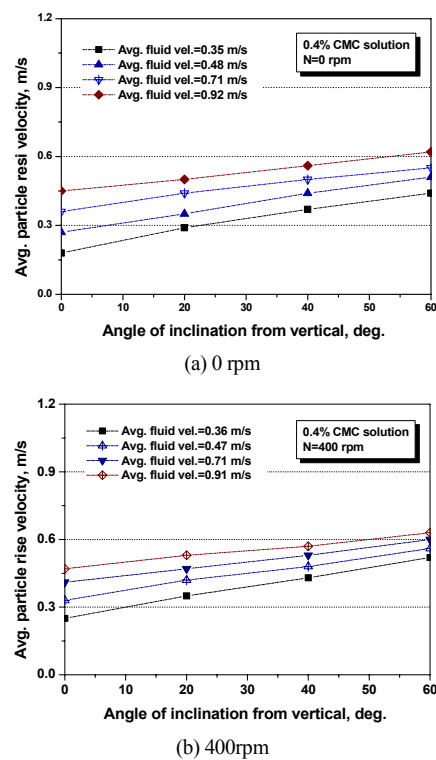

Fig. 4. Variation of particle rise velocity with annulus inclination and flow rate at (a) 0 rpm, and (b) 400 rpm in 0.4% CMC solution.

velocity of particles was gradually increased with the mixture velocity and rotation of the inner cylinder. The rise velocity shows an irregular pattern in the vicinity of annulus inclination of 45 degrees.

The minimum mixture fluid velocity for particle transport in 0.4% CMC solution is smaller than that in water. This is because of the viscosity of 0.4% CMC solution is about 16 times higher than that of water. Higher viscosity of fluid is effective for particle transport in a certain range.

Unlike vertical particle transport, the use of average particle rise velocity to evaluate particle transport performance in a directional well would be misleading due to bed formation and the concomitant reduction in effective flow area, leading to high effective fluid and particle velocities, as may be seen in Figs. 3 and 4. As the inclination of the annulus is increased over 40 degrees from the vertical, the velocity of particles is larger than the mixture fluid velocity.

As shown in Fig. 4, the particle rise velocity is faster in 400 rpm than in 0 rpm at the same flow conditions. Also, the particle volume concentration (C_{VT}) is slightly decreased in 400 rpm compared with in 0 rpm. From this, rotation of the inner cylinder generally improves the transport of solid particles, is more pronounced at lower mixture velocities, and appears to be negligible at high rotational speeds over 300 rpm. One explanation for this may be that at high flow rate, the mixture velocity is the dominating factor in the particle transportation, with rotational speed having marginal effects.

Successful and economic drilling of highly deviated slim hole wells requires the efficient transportation of cuttings to the surface. Figs. 5~7 show graphical correlations of C_{VT} in terms of several relevant drilling parameters. In these correlations it is important to remember that the total particle concentration can give a good indication of drilling fluids' transport efficiency.

The lower the particle concentration is the better the transport performance. From this point of view, it is obvious from Figs. 5~ 7 that drilling fluids in all flow regimes perform best at low angle of annulus inclination.

The particle concentration, C_{VT} is defined as follows:

$$C_{VT} = \frac{(Net\ volume\ occupied\ by\ particles)}{(Total\ annulus\ volume)} \times 100 \quad (3)$$

Fig. 5 shows the variation of C_{VT} as a function of flow rate and inclination of annulus. The C_{VT} is decreased as the flow rate is increased. However, the C_{VT} increases with the inclination of annulus. That is, the particle transport performance is declined.

The fluid velocity of 0.4% CMC solution is much smaller than that of water for solids transport at the same conditions as shown in Fig. 6. That is, the transport efficiency of 0.4% CMC solution is much better than that of water.

Moreover, the higher viscosity fluid gives better transport performance than the lower viscosity fluid. The effective viscosity of 0.4% CMC and 5% bentonite solutions is much higher than that of water and shows a shear-thinning behavior. That is, viscoelastic fluids have been observed to provide better capability to mobilize and transport particles. As shown in Figs. 6 and 7, 0.4% CMC and 5% bentonite solutions can transport sand particles at lower mixture velocities compared to those of water.

Fig. 7 shows the transport efficiency of 5% bentonite solution compared to 0.4% CMC solution. The transport efficiency of 5% bentonite solution is

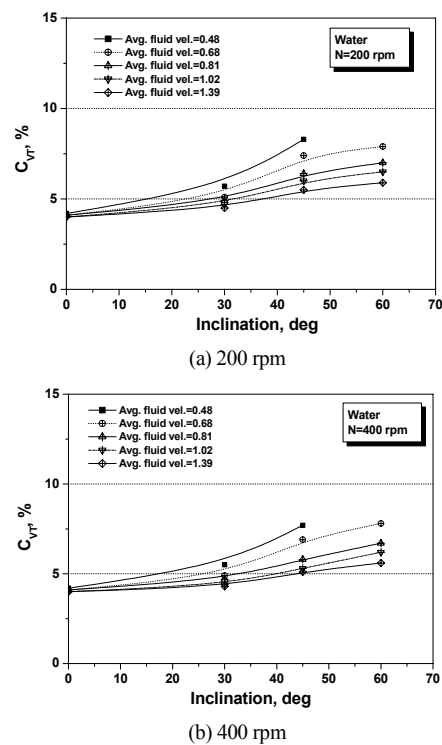

Fig. 5. Variation of particle volume concentration with annulus inclination and flow rate at (a) 200 rpm, and (b) 400 rpm in water.

obviously improved over 0.4% CMC solution. The main reason of this improvement is the specific gravity of 5% bentonite solution is several times higher than that of 0.4% CMC solution. From this, fluid viscosity and density are important elements in the drilling fluid design.

The viscosity is effective for the particle transportation in a certain range. But the particle transport performance is not improved continuously with the viscosity as shown in Figs. 5 and 6. In this case it is necessary to decrease the densities between particle and carrier fluid.

The effect of inner pipe rotation on particle concentration is also shown in Fig. 5. Rotation of the inner cylinder helped to prevent a bed of cuttings being formed. Certainly, the effects of pipe rotation from this graph, is minor at best and mostly negligible. The repeated experiments show that $\pm 5\%$ error in the solid particle velocity measurements and $\pm 9\%$ error in the particles concentration measure-

ments.

Accurate pressure calculation is crucial for safely controlling formation pressures and protecting wellbore integrity. It is more difficult in slim hole drilling than in conventional drilling. Variations in annular geometry, annulus inclination, and pipe rotational speed strongly affect pressure loss of a fluid flowing in the narrow annulus of a slim hole well.

In slim hole annular flow, it is important to remember that because of the reduced annular clearance the effect of the pressure losses is different than that experienced in conventional drilling. In conventional drilling 90% of the pressure losses occur in the drill pipe and through the bit nozzle. In slim holes up to 60% of the pressure losses occur in the annulus (Saggot et al. [9]).

The pressure drop versus mixture velocity and annular inclination are shown in Figs. 8 and 9, for the mean particle size of 0.2 cm and sand volume fraction of 4%. The carrier fluids are water, 0.4% CMC, and

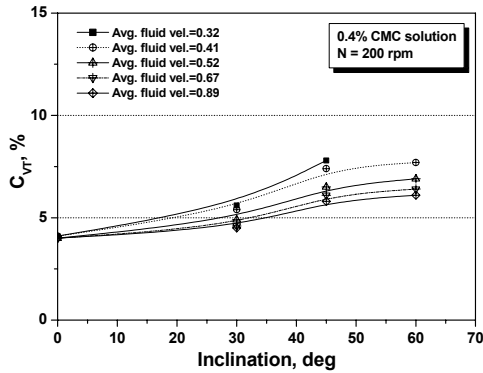

(a) 200 rpm

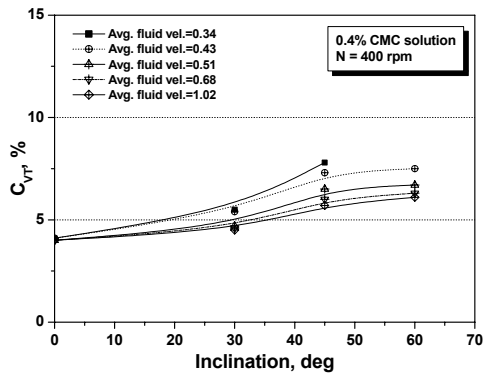

(b) 400 rpm

Fig. 6. Variation of particle volume concentration with annulus inclination and flow rate at (a) 200 rpm, and (b) 400 rpm in 0.4% CMC solution.

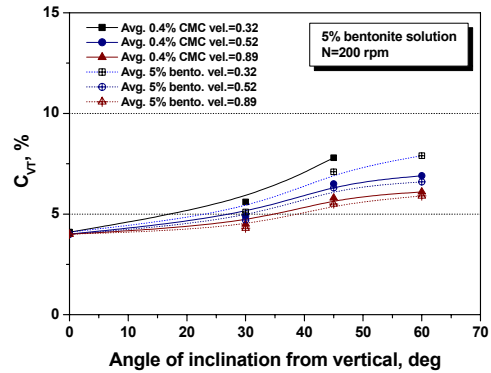

(a) 200 rpm

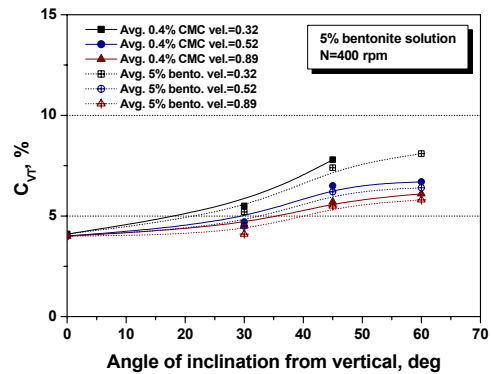

(b) 400 rpm

Fig. 7. Variation of particle volume concentration with annulus inclination and flow rate at (a) 200 rpm, and (b) 400 rpm in 5% bentonite solution.

bentonite solutions.

Unlike single phase flow, the pressure drop of solid-liquid mixture flow is changed with the change of annulus inclination. The additional effect of the gravitational force results in a monotonic change of the pressure drop as the angle of inclination is increased. This flow pattern is more prevalent as the

annulus inclination is increased because of the bed formation and increased friction between particles and wall or among particles.

As shown in the figures, the pressure drop increases along the increase of mixture fluid velocity and annulus inclination, but the characteristic shape of the pressure drop curve is not changed. Also, the

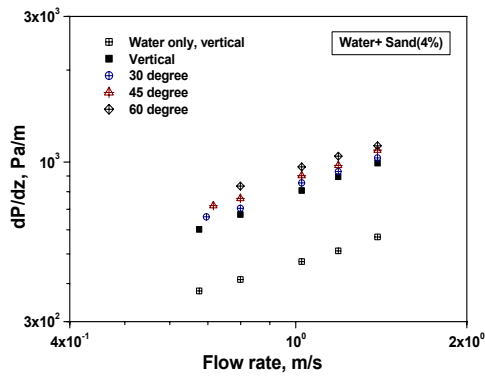

(a) Water

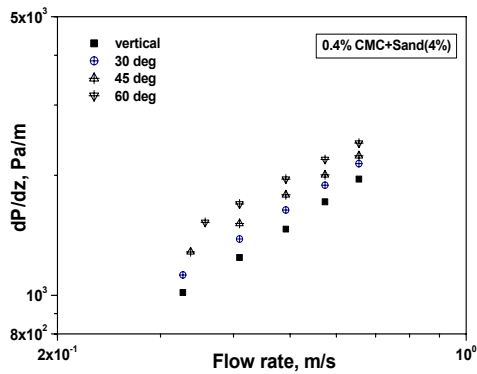

(b) 0.4% CMC solution

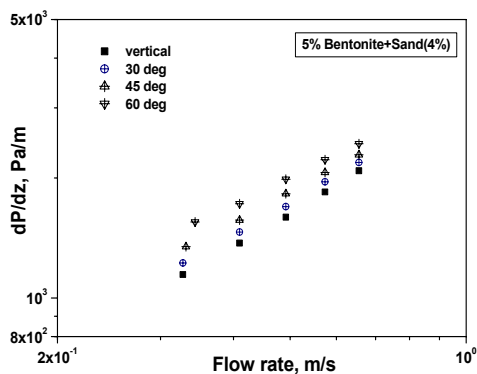

(c) 5% bentonite solution

Fig. 8. Variation of pressure drop with annulus inclination in added sand (4%) and (a) water, (b) 0.4% CMC solution, and (c) 5% bentonite solution at 0 rpm.

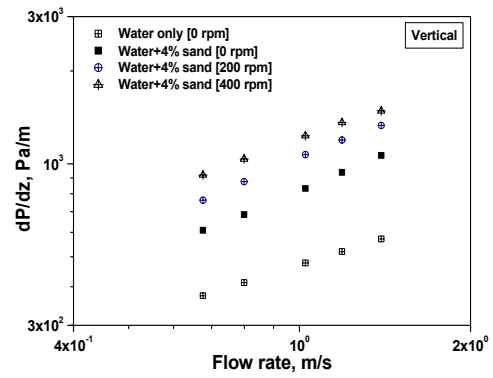

(a) Water

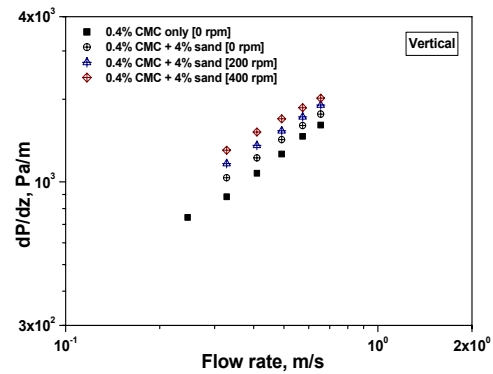

(b) 0.4% CMC solution

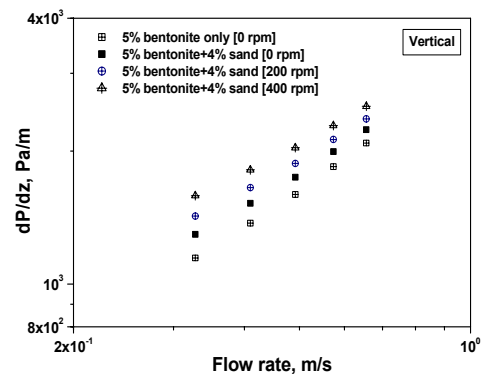

(c) 5% bentonite solution

Fig. 9. Variation of pressure drop with rotational speed and solid concentration in (a) water, (b) 0.4% CMC solution, and (c) 5% bentonite solution.(Inclination = 0 degree)

pressure drop of solid-liquid mixture flow increases abruptly compared to the single phase fluid flow. The pressure drop of solid-liquid mixture flow increases due to the friction between the wall and solids or among solids.

It is difficult to compare directly the pressure drop among the three fluids, because of the mixture fluid velocity of water is larger than the other fluids. But the pressure drop of solid-liquid mixture flow is increased with the increase of the viscosity of the carrier fluid.

The inclination of the annulus affects the magnitude of the pressure drop. The pressure drop increases as the viscosity of carrier fluid is increased. The viscosity of carrier fluids is increased in order of water, 0.4% CMC, and 5% bentonite solutions.

Fig. 9 shows the pressure drop of solid-liquid mixture flow with rotation of inner cylinder in a vertical annulus. As shown in Fig. 8, the pressure drop increases with increasing axial flow rate and it also increases with the rotational speed of the inner cylinder. The pressure drop in mixture flow is much more increased compared to pure liquid flow in Fig. 9(a). The friction between the wall and solids or among solids is increased by the rotation of the inner cylinder.

The effect of the inner cylinder rotation on the pressure drop is largest in water and it becomes weak in 0.4% CMC and 5% bentonite solutions. This is because the resistance against the flow of shear thinning fluid decreases with increasing shear rate.

4. Conclusions

Steady laminar and turbulent upward flows of solid-liquid mixture flows through a concentric annulus have been investigated experimentally.

The use of an average particle rise velocity to evaluate particle transport performance in an inclined annulus would be misleading due to bed formation and concomitant reduction in effective flow area, leading to high effective fluid and particle velocities.

The particle transport performance of 5% bentonite solution is superior to that of 0.4% CMC solution. There is no great difference in viscosity of two the fluids, but the specific gravity of 5% bentonite solution is larger than that of 0.4% CMC solution. Viscosity and density of fluids are the important factors in the design of drilling fluids.

The pressure drop in a solid-liquid mixture flow

increases with the mixture flow rate, inclination of annulus, and rotation of the inner cylinder. For a solid-liquid mixture flow, the hydraulic pressure drop increases largely compared to single phase flow due to the friction between the wall and solids or among solids.

Rotation of the inner cylinder generally improves the transport performance of particles. It is more pronounced at lower mixture velocities and appears to be weakened at high flow rate. The effect of the inner cylinder rotation on the pressure drop is largest in water and it becomes weak in 0.4% CMC and 5% bentonite solutions. This is because the resistance against the flow of shear-thinning fluid decreases with increasing shear rate.

Acknowledgment

This work was supported by the Brain Korea 21 Project in 2007.

References

- [1] P. H. Tomren, A. W. Iyoho and J. J. Azar, An experimental study of cuttings transport in directional wells, SPE Drilling Engineering, SPE 121, (1986).
- [2] J. T. Ford, J. M. Peden, E. G. Oyenyin and R. Zarrough, Experimental investigation of drilled cuttings transport in inclined boreholes, SPE Annual Technical Conference, New Orleans, Sept. 23-26, SPE 20421, (1991).
- [3] R. J. S. Pigott, Mud Flow in Drilling, Drilling and Production Practice, API, (1941), 91-103.
- [4] T. R. Sifferman, et al., Drill-Cuttings Transport in Full-Scale Vertical Annulus, Journal of Petroleum and Technology, (1974), 1295-1302.
- [5] A. Sellgren, The choice of operating velocity in vertical solid-water pipeline systems, BHRA Fluid Eng., Paper D3, (1982), 211-226.
- [6] T. A. Ozbelge and A. Beyaz, Dilute solid-liquid upward flows through a vertical annulus in a closed loop system, Int. J. of Multiphase flow, Vol. 27, (2001), 737-752.
- [7] Y. J. Kim and Y. K. Hwang, Experimental Study on the Vortex Flow in a Concentric Annulus with Rotating Inner Cylinder, KSME International Journal, 17 (4) (2003), 562-570.
- [8] R. V. Lauzon and K. I. B. Reid, New Rheological Model Offers Field Alternatives, Oil and Gas Journal, 77 (1979), 51-57.

- [9] A. M. Saggot and D. C. Dupuis, A Major Step in Ultra Slimhole Drilling, SPE Drilling Engineering, SPE 28299, (1994), 81-90.



Sang-Mok Han received a B.S. degree in Mechanical Engineering from Sung-kyunkwan University in 2001. He then went on to receive his M.S. degrees from Sungkyunkwan University in 2003. He is a candidate for Ph.D. from 2006 to

the present at the School of Mechanical Engineering at Sungkyunkwan University in Suwon, Korea. His research interests are in the area of Multi-phase flow and drilling.



Nam-Sub Woo received a B.S. degree in Mechanical Engineering from Sungkyunkwan University in 1997. He then went on to receive his M.S. and Ph.D. degrees from Sunkyunkwan University in 1999 and 2007, respectively. Dr. Woo is

currently a Senior Researcher at the Fire & Engineering Services Research Center at Korea Institute of Construction and Technology in Goyang, Korea. Dr. Woo's research interests are in the area of fluid dynamics and plant engineering.



Young-Kyu Hwang received a B.S. degree in Mechanical Engineering from Sungkyunkwan University in 1977. He then went on to receive his M.S. from University of Wisconsin at Madison in 1980 and Ph.D. degrees from State University of

New York at Buffalo in 1984, respectively. Dr. Hwang has served as a Professor, from 1984 to the present at the School of Mechanical Engineering at Sungkyunkwan University in Suwon, Korea. His research interests are in the area of drilling hydraulics, molecular gas flow and hydrodynamic instability.